

## Solid-Motion SGA01 User Instructions



The Solid-Motion SGA01 is designed to amplify and filter small voltage and current sensor output signals, such the output signals from a strain gage or pressure sensor. The output of the SGA01 ranges from 0 to 10V and may be connected to an analog-to-digital converter (ADC), such as a Dataq, for digitization and display on a PC.

A battery voltage of anywhere from 12V to 24V may be used to power the SGA01 and battery connections for two 9V batteries are already assembled on the board.

### Features

Available in any gain from 1 to 1000. Stock gains are 10, 100, 333, and 500

Available in any bandwidth from 1 to 10KHz.

2-pole butterworth output filter

Very low noise. Less than 0.5LSB into a 12 bit ADC

10V excitation voltage with continuous short-circuit current limiting

High impedance 1 Megohm differential input

10ppm low TC, 0.1% gain setting resistor

0-10V output. 0-5V output also available

Diode protected battery connection. Accidentally reversing the supply connection won't destroy the amplifier

High quality Phoenix terminal block connectors

Supply voltage 12V to 24V

Custom gains and bandwidths on request.

## Specifications

### *Amplifier Section*

Gain/sensitivity	As ordered
Bandwidth	As ordered
Input voltage range	10V/gain
Output voltage range	10V
Maximum input voltage	±40V
Input impedance	1 Megohm
Nonlinearity	±0.01%
Gain tempco	±100ppm/°C
Offset voltage drift	(gain)x(±2μV/°C)

### *Excitation Voltage Section*

Voltage error	±0.5%
Voltage drift	±35ppm/°C
Excitation current (max in linear range)	40mA
Excitation current (short circuit)	(gain)x(±2μV/°C)

## SGA01 Connections

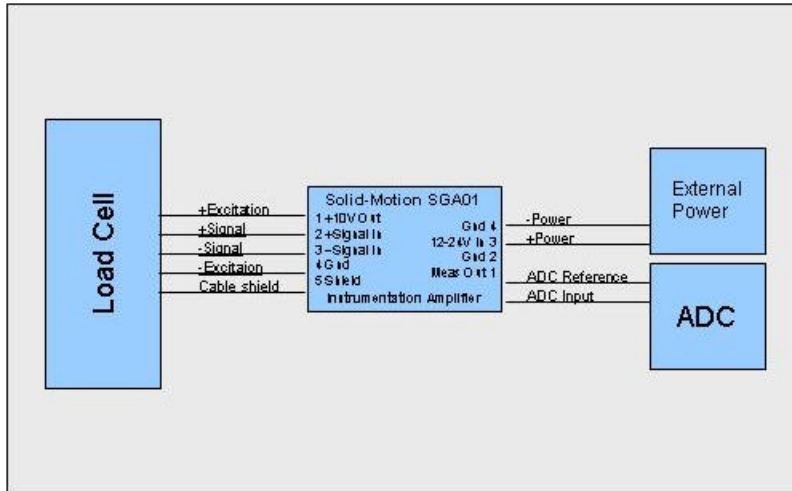

1. Hook up the sensor as indicated. Note that while the SGA01 provides common mode rejection, it does not provide signal isolation. In other words, the input ground and the output ground are connected and at the same potential.
2. Hook up a 12V to 24V power source. Two 9V batteries wired in series can be used. After power is applied, 10V should appear on the +Excitation terminal on the input.
3. Hook up the ADC reference to pin 2 of the output. Hook the ADC input to pin 4 (Meas).

## 4. Schematic

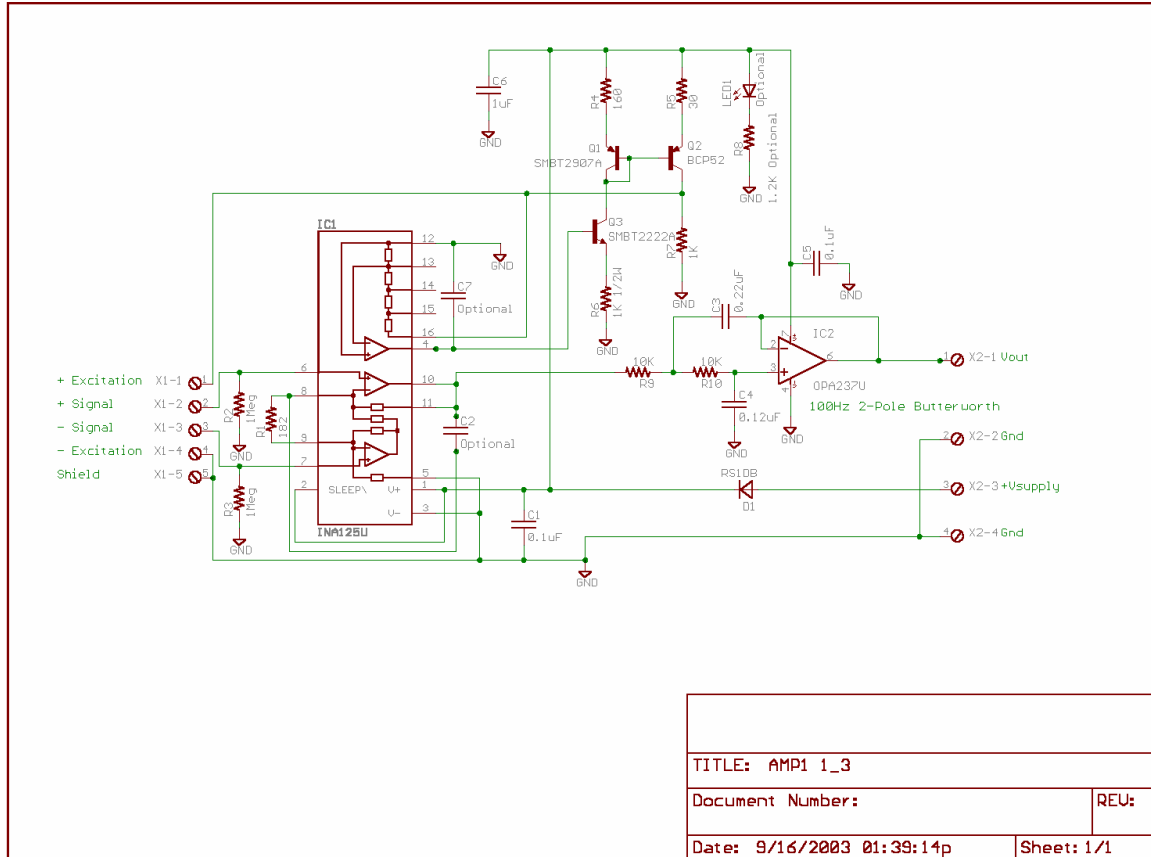

## Troubleshooting

If no signal shows up in the Dataq oscilloscope with a weight on the load cell try these fixes:

1. Make sure the supply voltage is at least 12V.
2. Is there ~10V excitation voltage? If not check to make sure the excitation output isn't shorted.
3. Try reversing the + and - sense leads of the load cell. Sometimes load cells are mismarked.